

# VISOGLIDE + INSTALLATION GUIDE

Please read guide before beginning any installation.



**TOTAL**  
Aluminium Solutions



- |   |   |   |
|---|---|---|
| Instructions/Guides <input type="checkbox"/>          | Cill End Caps <input type="checkbox"/>        | Screws for keeps final fixing (4.2 x 45) <input type="checkbox"/>                     |
| Keys & Handle Screw Covers <input type="checkbox"/>   | Drainage Caps <input type="checkbox"/>        | Screws for fixed door (4.2 x 65) <input type="checkbox"/>                             |
| Interlock Covers <input type="checkbox"/>             | Night Vents <input type="checkbox"/>          | Screws for slim interlock through glazing channel (3.9 x 13) <input type="checkbox"/> |
| Anti-Lift & Rubber Stops <input type="checkbox"/>     | Glass Packers <input type="checkbox"/>        |   |
| Anti-Lift for Slim Interlock <input type="checkbox"/> | Glass Perimeter Foam <input type="checkbox"/> |   |
| Stoppers <input type="checkbox"/>                     | Wedge Gasket <input type="checkbox"/>         |   |

## Kit Form

- |                |                          |
|----------------|--------------------------|
| Cleats         | <input type="checkbox"/> |
| Tension Blocks | <input type="checkbox"/> |
| Chevrons       | <input type="checkbox"/> |
| Glue           | <input type="checkbox"/> |

1. Cover
2. Index
3. Kit Form Assembly
4. Head Extension / Add-on
5. Installing the Outer frame & Thermal Tape (for outer frames with upstand)
6. Frame Closers
7. Installing Door Sashes
8. Installing Door Sashes (continued)
9. Drain Trays
10. Interlock Mullion
11. Anti-Lift Guides
12. Slim Interlock Fitting Guide & Slim Interlock Cover Trim
13. Bonding of Slim Interlock
14. Door Stopper & Glass Perimeter Foam (see note regarding slim interlock)
15. Cover Plate for Threshold & Sides

1. Degrease saw cut
2. Seal all the faces with good quality silicone (not supplied). All bare metal edges should have a thick bead applied, as should the thermal break and insert.
3. Fix the corner cleats with a 2.5mm hexagonal key.
4. On occasions this may be a 3mm allen key. (These are not supplied)
5. It is important that after the joint has been made to smother the outer corner where the cleat blocks fit to ensure no water ingress at the side and bottom.
6. Repeat process for all four corners.

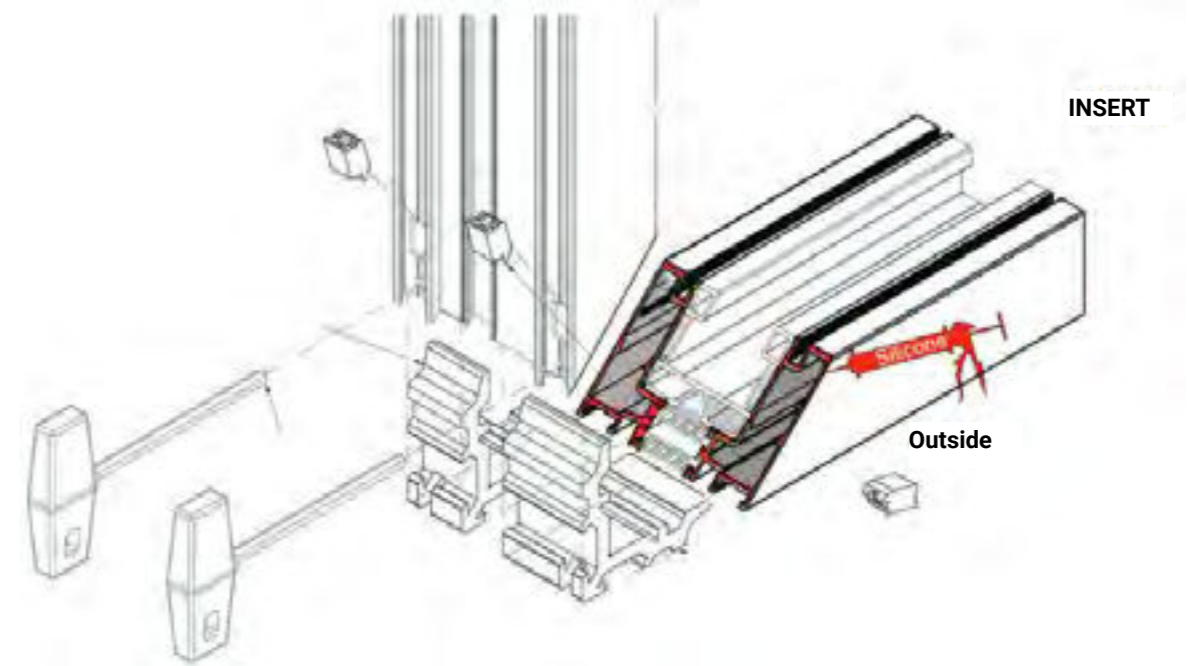

**INSTALLING THE OUTER FRAME**

**INSTALLATION CHECKLIST**

Frame will fit in the opening with out distortion	
Head/Bottom of the frame fixed straight and level +/-2mm	
Sides fixed plumb	
Ensure outer frame is true and square	
Lock operation tested and working	

## HEAD EXTENSION

The head extension is fitted using the supplied fitting blocks. Flat pack add-on is fitted to the top for delivery. This must be removed to put the frame together.

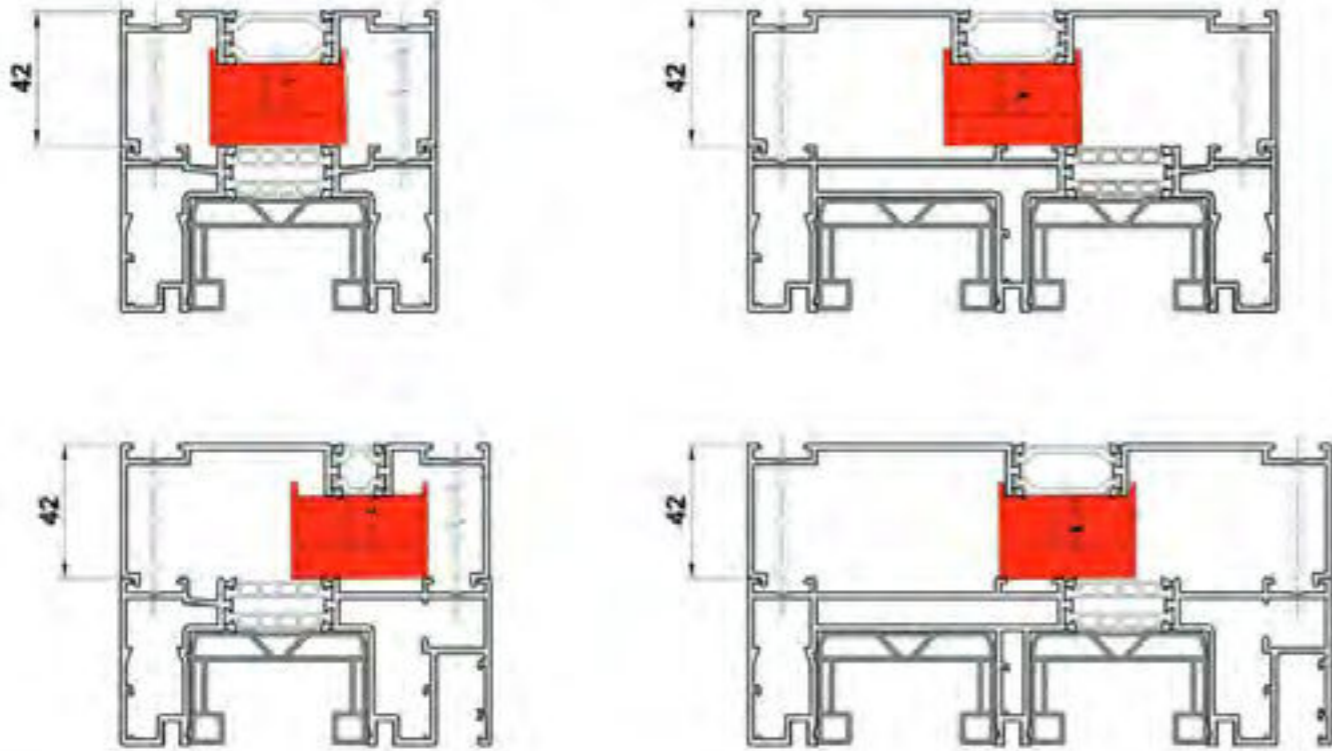

## INSTALLING THE OUTER FRAME

Please note our Patio doors are, wherever possible, supplied assembled and tested. However in some cases due to size & weight they are supplied in kit form, for this reason it is imperative to read this booklet before attempting installation.

1. Firstly check the frame will fit the structural opening and it isn't tight to the brick, ideally 10mm to 15mm clearance required, also check how level the opening is.
2. Ensure the structural opening is clean and free from debris and old silicone.
3. Fit any add-ons if applicable and lift frame into the opening. Take care when handling the frames as they are heavy and awkward. Be careful not to catch the frame on any brickwork
4. Ensure the apertures load bearings are not transferred to any part of the frame when fitted.

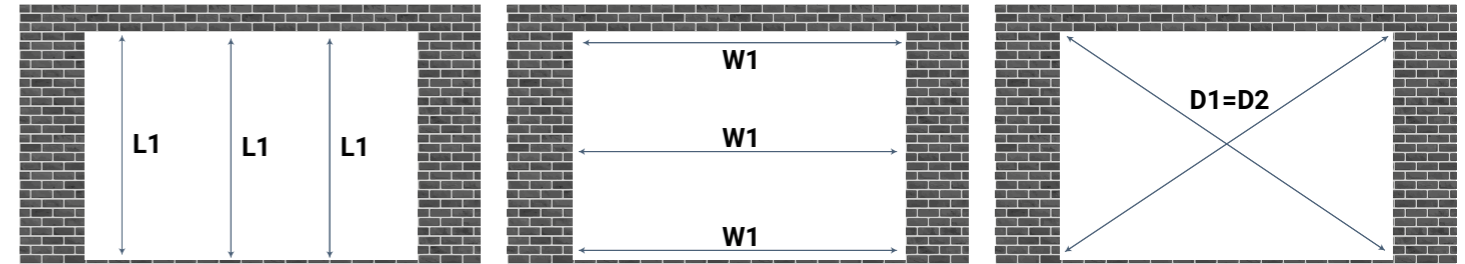

5. Once the frame is in the aperture you will need to 'pack it' into place. Ensure it is all plumb, level and square by using a spirit level & measure all three dimensions at regular intervals ensuring the frame is packed regularly down the sides and across the head. Ensure the frame isn't over packed causing any bows or bends. Ideally packing will be at the fixing points
6. Now you can start to fix the frame into the structural opening. Ideally start approx. 150mm from the corner of the frame and then at a maximum spacing of approx. 600mm. Repeat this around the frame checking there is sufficient packing around the fixtures and that after tightening check again for any bowing, twisting and that all is square. Adjust as required. Taking care here will save time during the rest of the installation

### THERMAL BARRIER TAPE - NOT SUPPLIED BY TOTAL

When an outer frame with an upstand is required that sits on a cill it is necessary to use a thermal barrier tape to stop the bridging of the thermal break.

This is normally fitted to the bottom of the frame but can also be placed along the cill, this is purely to stop heat/cold transfer.

Once you have fitted the patio to the cill it will be necessary to run a small bead of silicone over the joining face as is standard practice.

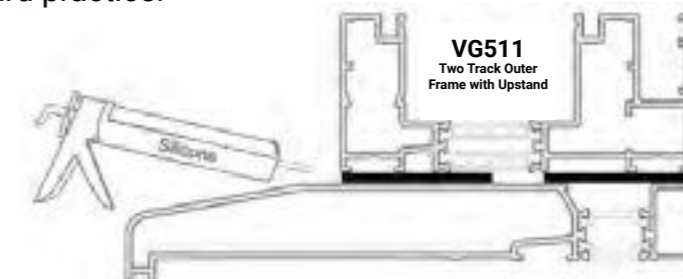

## INSTALLING THE OUTER FRAME

Rubber seals are fitted to the top & bottom of all frames where the interlocks meet. These are normally factory fitted; the only exception to this is on large, split frames

If the closers need to be fitted on site then it must be done before all the doors are in the frame.

You can either measure out the distances or you can fit the first door roughly in place and locate the closer, apply silicone as shown then move onto the next door.

It should sit equally underneath the interlocks and is held in place by simply applying silicone as indicated.

Until the silicone has set please take extra care when sliding the doors as the closers may drag and move.

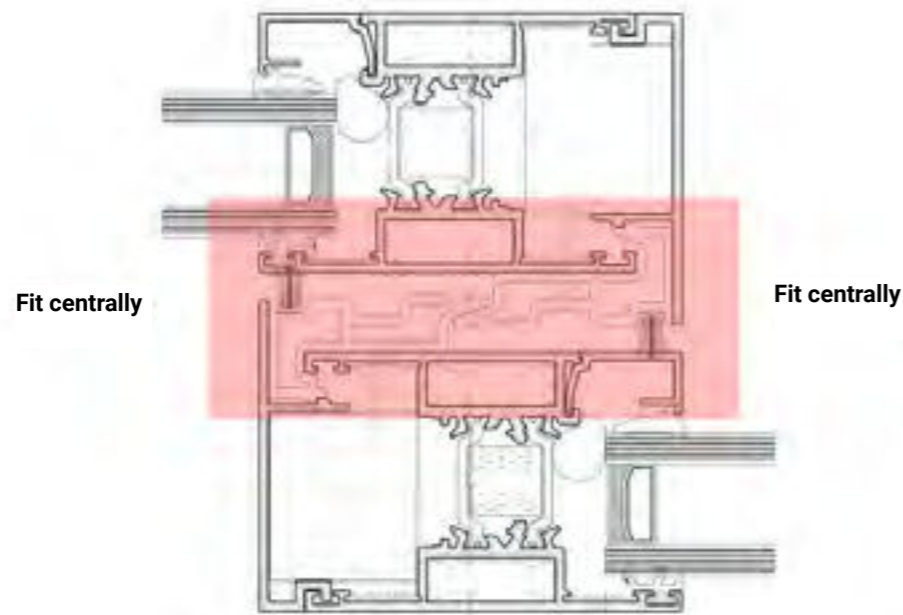

Apply silicone in centre hole after installation

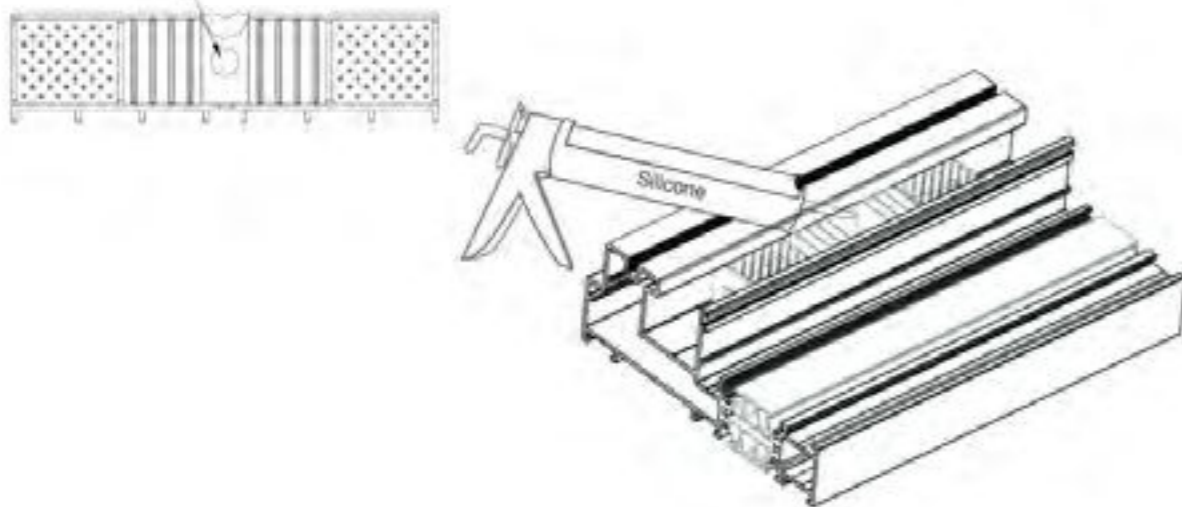

## INSTALLING THE DOOR SASHES



Locate the top of the door sash to the head of the outer frame ensuring the cut-outs line up with the frame. Check angle at which the door sash is being inserted as if its too great or too small it will result in damage to the item. Once the door sash is inserted into the head of the outer frame the bottom should be able to swing into the bottom of the outer frame and locate onto the track.

N.B. This is normally a tight fit so a slight flex in the frame can be helpful.

Sliding doors are fitted to the **INSIDE** as standard. Fixed door seals to the frame with a gasket as opposed to a brush seal to aid weatherproofing. We do not fit gasket to the sliding doors as this can scratch and scuff as the doors slides along.

**FIXED DOORS SLIDE ONTO THE FIXING BLOCKS FITTED INTO THE OUTER FRAME**

**To set up the doors we recommend installing all of the doors, locking the master then setting the fixed door to suit so that the interlocks meet correctly.** This is the same principle for 3/4 doors etc.

Please remember that all sliding doors should have some side to side movement when closed. The interlocks should not meet too tightly, for example on a 3 door all sliding the centre door should have around 5mm of side to side movement. This is normal to allow for expansion / contraction.

Once satisfied, screw the fixed door into position. In some instances, it may be necessary to remove the black support blocks to allow the sash to overlap the frame more to ensure the interlocks meet correctly. To do this simply unscrew the block. Apply silicone to any holes to seal and protect.

## INSTALLING THE DOOR SASHES (CONT....)

Set the door to the required position (remember doors should have a small amount of side to side movement to allow for expansion / contraction). No movement or too excessive movement means the fixed door needs moving over.

Screw the sash to the frame at the top and the bottom using the packers provided as washers. **DO NOT OVER TIGHTEN.**

Do the same down the side but pay attention to ensure you do not bow or twist the sash.

It is useful to use the glazing packer supplied as a washer for the screw so you don't damage the thermal break by over tightening. Ensure the screws will not interfere with the glass. Bed with silicone where the door is screwed in.

Once the doors are fully glazed it may be necessary to make a slight adjustment to the keep as the doors may have moved. We do not fit the keep in position for this reason.

Simply loosen the screws in the keep, slide as required and re-tighten. Once you are satisfied it is in the correct position install the fixing screws provided to secure it.

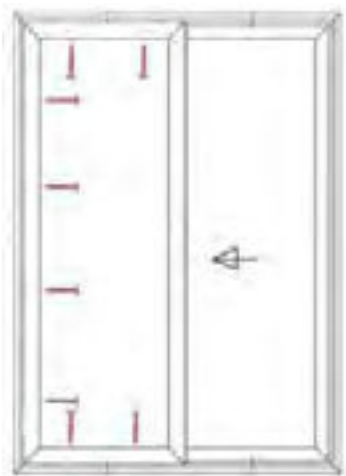

Fix 100mm from ends then approx every 1000mm maximum

Position of fixing blocks, obviously depending on style of patio



Keep

## DRAIN TRAY

To aid the drainage and appearance of the bottom track a drain tray will be fitted as per the diagrams below.

Their aim is to direct the water down and into the drain channel but to also eliminate the sight of standing water.

These are normally factory fitted but on large kit forms they may need to be site fitted. Simply screw on the retaining clip at no more than 500mm centres. Cut the drain tray to size, if closers are fitted then cut up to this. It then simply clips into place.

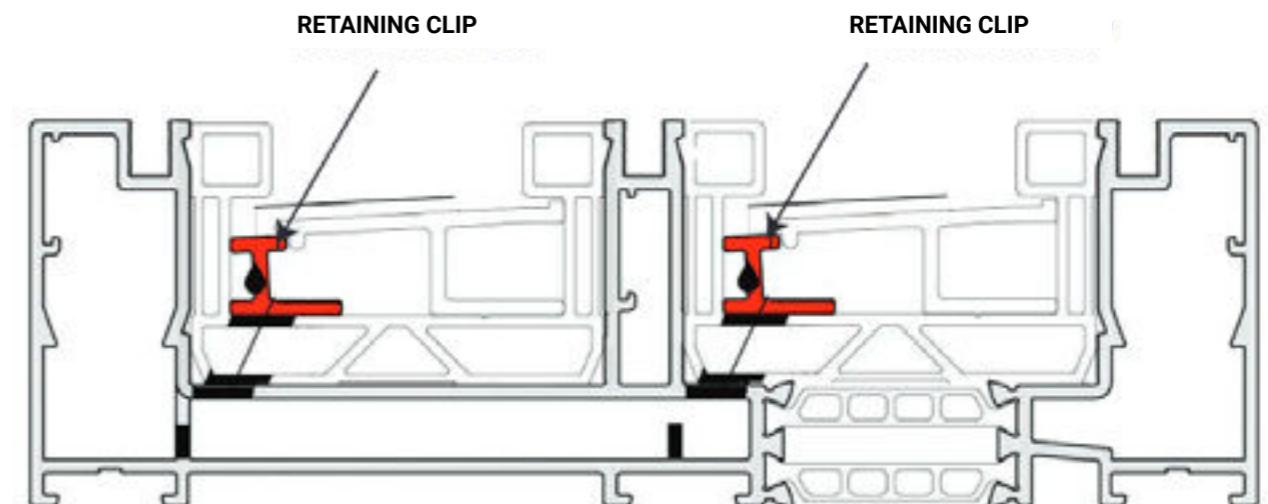
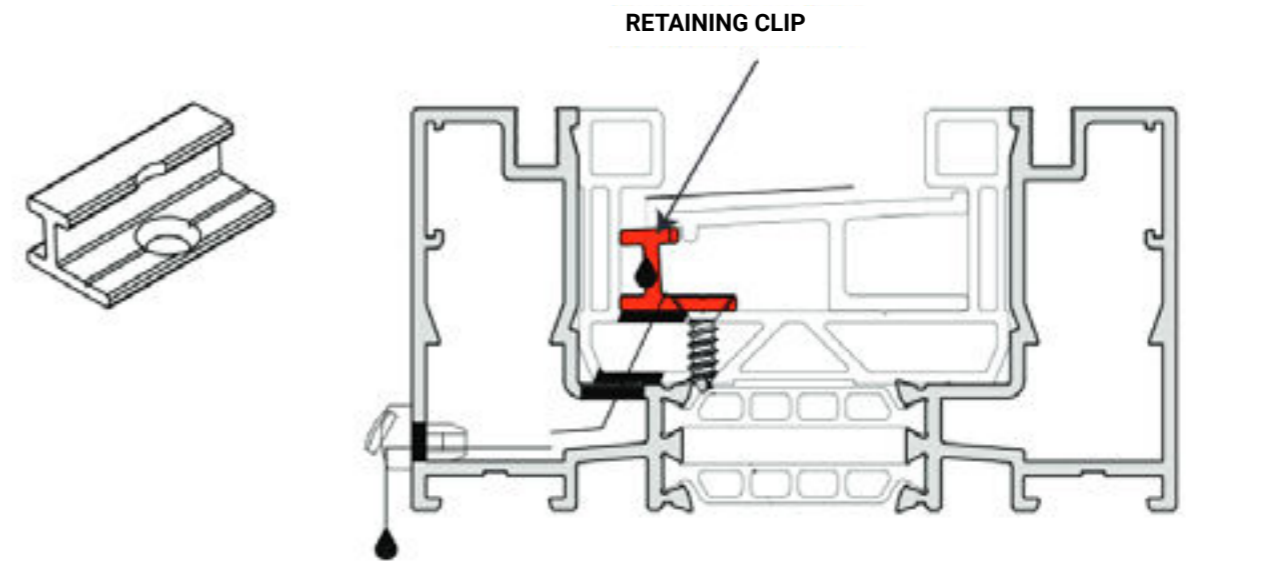

## INTERLOCK MULLION

If you have to fit the interlock to the doors use the screws and plates provided. Ensure the screws do not protrude into the glass unit, cut back if necessary.

The keep locates into the channel and will require adjusting after fitting by loosening the screws and sliding into the required location. Once in the correct position, fix the keep into place.

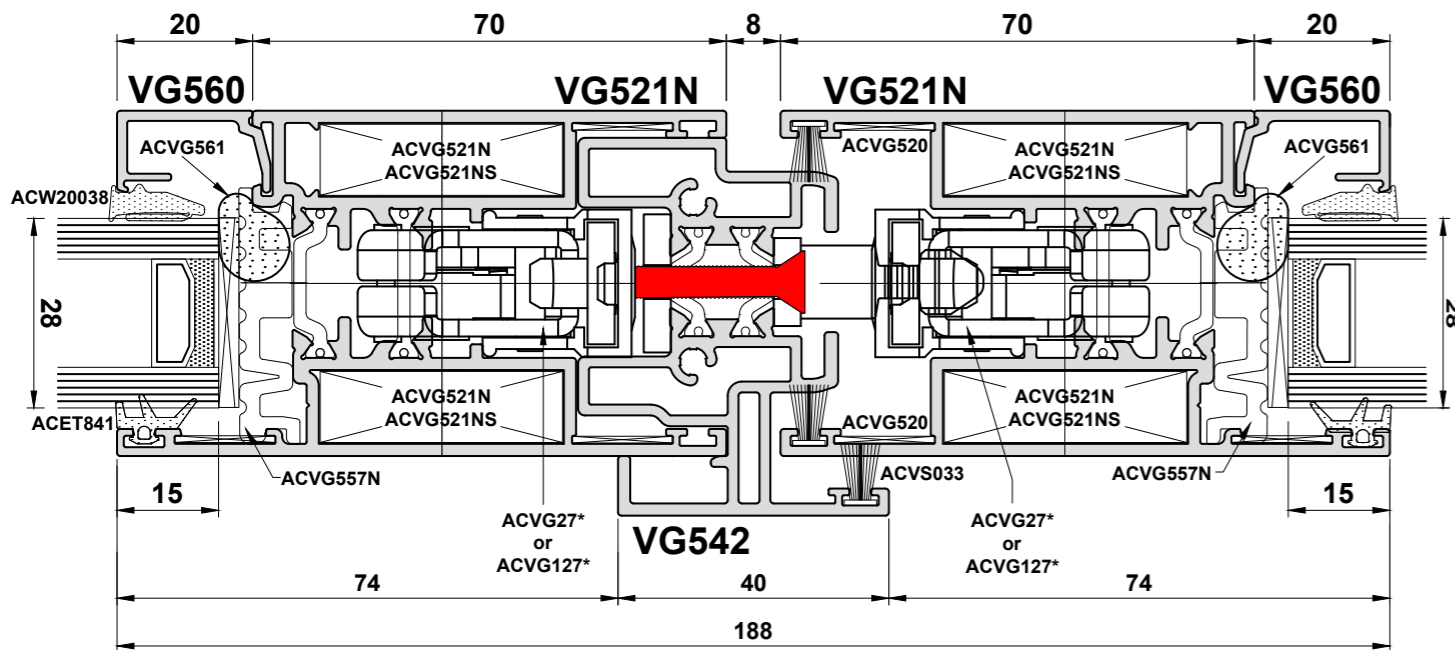
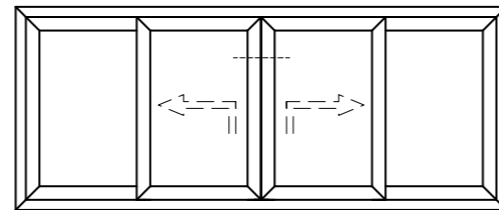

## ANTI-LIFT GUIDES

Anti-lift guides are fitted to all sashes.

On fixed doors they are installed on the interlock side (top & bottom) but not on the frame (wall) side, this is to eliminate movement.

On sliding doors they are fit to the top of both sides and the bottom of the lock side.

The lock side anti-lifts (top & bottom) also double up as buffer stops.

Anti-lift guides come in 3 sizes.

ACVG546 – is slim and used for slim interlocks.

ACVG545 – is slim with a narrow head for behind the interlock mullions.

ACVG529 – is large and used on standard interlocks and as buffers.

On the lock side a rubber bung is pushed into the anti-lift to act as a buffer.

Take care when screwing these on as if it is done incorrectly they can drag causing a binding feeling.

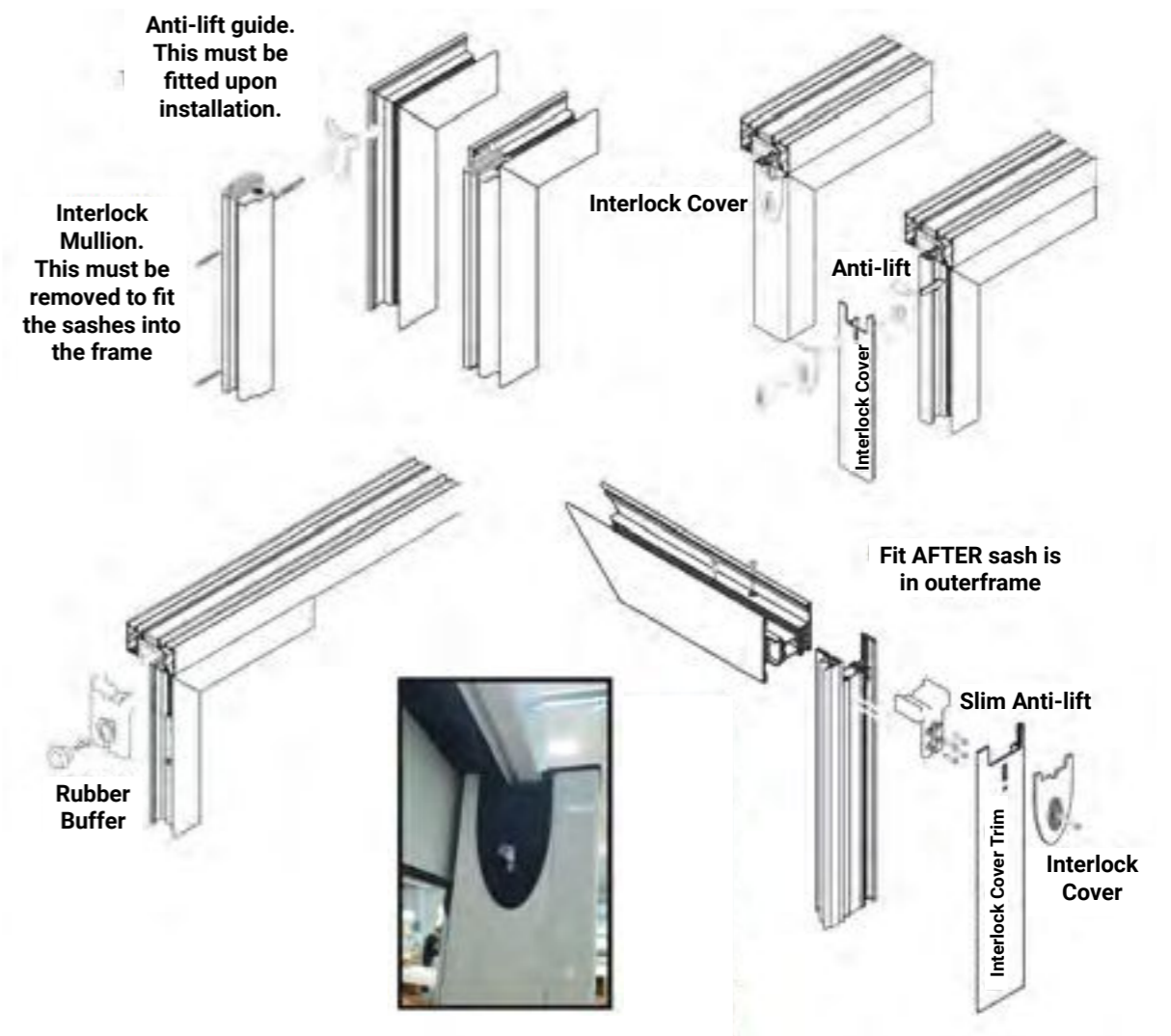



Fit the first door onto the track – DO NOT glaze at this point

Fit the Anti-Lift guides onto the sashes

Fit the interlock cover trim – this simply clips on.

Fit the interlock end covers and screw into place.



We use cut out in the cover plate so there is no need to screw through the channel – this is the final fixing for this trim.

Once This has been done you can insert the brush strip. This simply clips into the plastic interlock.

As it is plastic we recommend using a touch of silicone to secure it in place to stop any future movement.

This must be done before glazing otherwise you will not have access

Repeat for all doors.

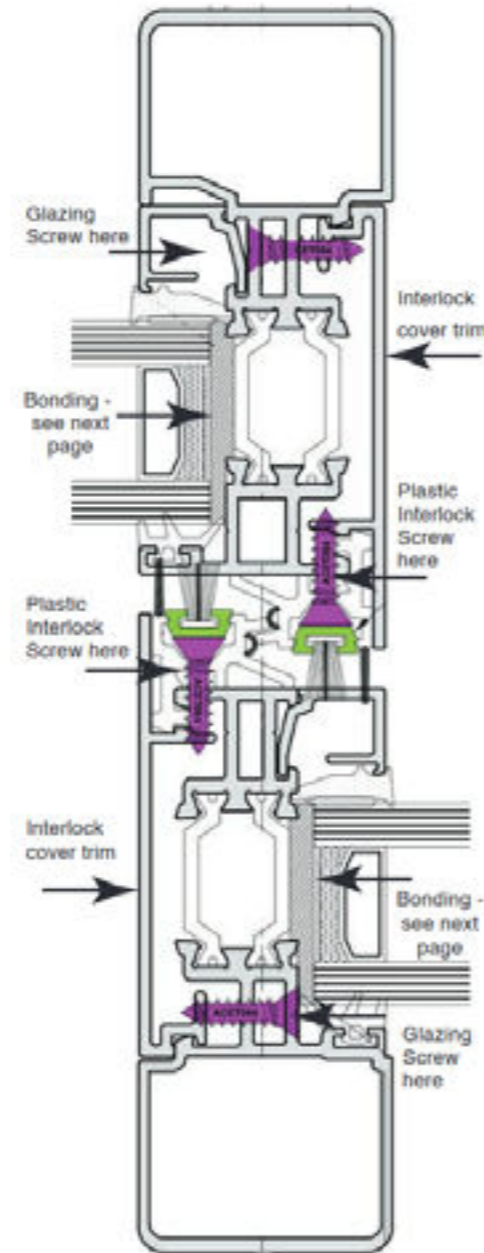

A bonding sealant must be applied to the full height of the slim interlock side to prevent any deflection. This is supplied in your box and must be done upon installation.

\*Note the unit must be untaped and be dust and dirt free.

Pack the glass into position within the sash.

Insert the sealant into the space between the glass and the slim interlock.

You must ensure the full height is bonded but take care not to bow or twist the sashes as this will cause issues.

**\*\*Please be aware that once this has been bonded it must be left overnight so it can set. The door cannot be used during this time.**

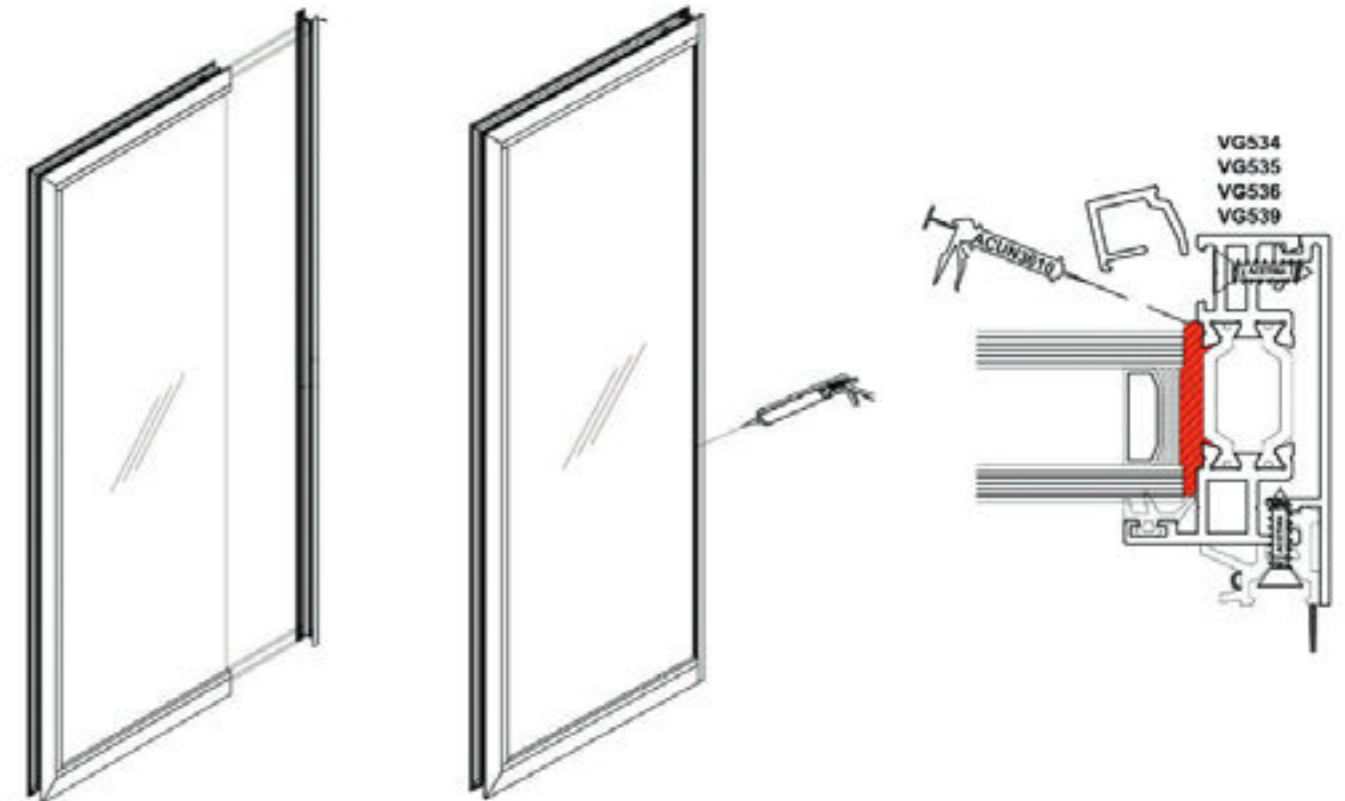

## STOPPER & GLASS PERIMETER FOAM

Before drilling for fitting ensure it will not interfere with the wheels and glass.

**Ensure handle does not interfere with interlock before fitting stopper.**

1. Drill holes as below into fixed pane (drill bit not provided).
2. Locate lug on stopper into hole.
3. Screw stopper to the side of the fixed panel.



Ensure you mark the correct door and as always measure twice before drilling

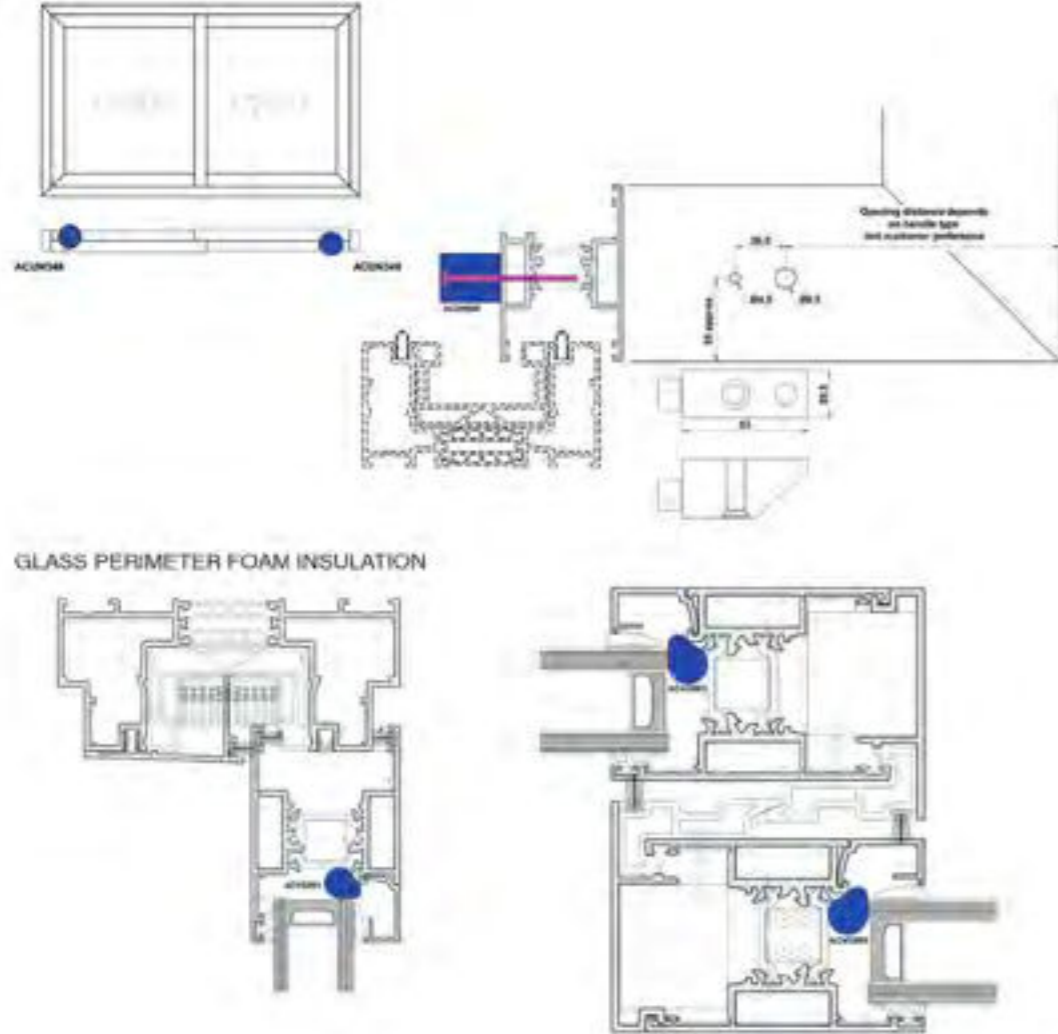

Before starting to glaze please be aware that the glass will be a snug fit. It is designed to be this way to support the interlock and help with rigidity. Also note that the glass should be untaped.

After installation of the glass and correct packing you can now fit the glass perimeter foam (grey foam tubing supplied in the box). This is simply a push in foam that helps to increase the weather protection of the doors. Cut to the length required (glass size + 100mm) and push into the gap between the glass and the sash as illustrated in the pictures. It is normal to start at the top corner and work your way around.

Please note that if you have a slim interlock the glass perimeter foam is only required for 3 sides - it is not required for the interlock side as this should be bonded, please refer to previous page.

## COVER PLATE FOR THRESHOLD & SIDES

These are supplied cut at a 2 degree angle on one end and supplied slightly longer so that they can be cut on site after installation of doors to ensure the best fit possible. Once installation is complete, cut to size and fit by tapping gently with a rubber mallet. Ensure they are a snug fit.

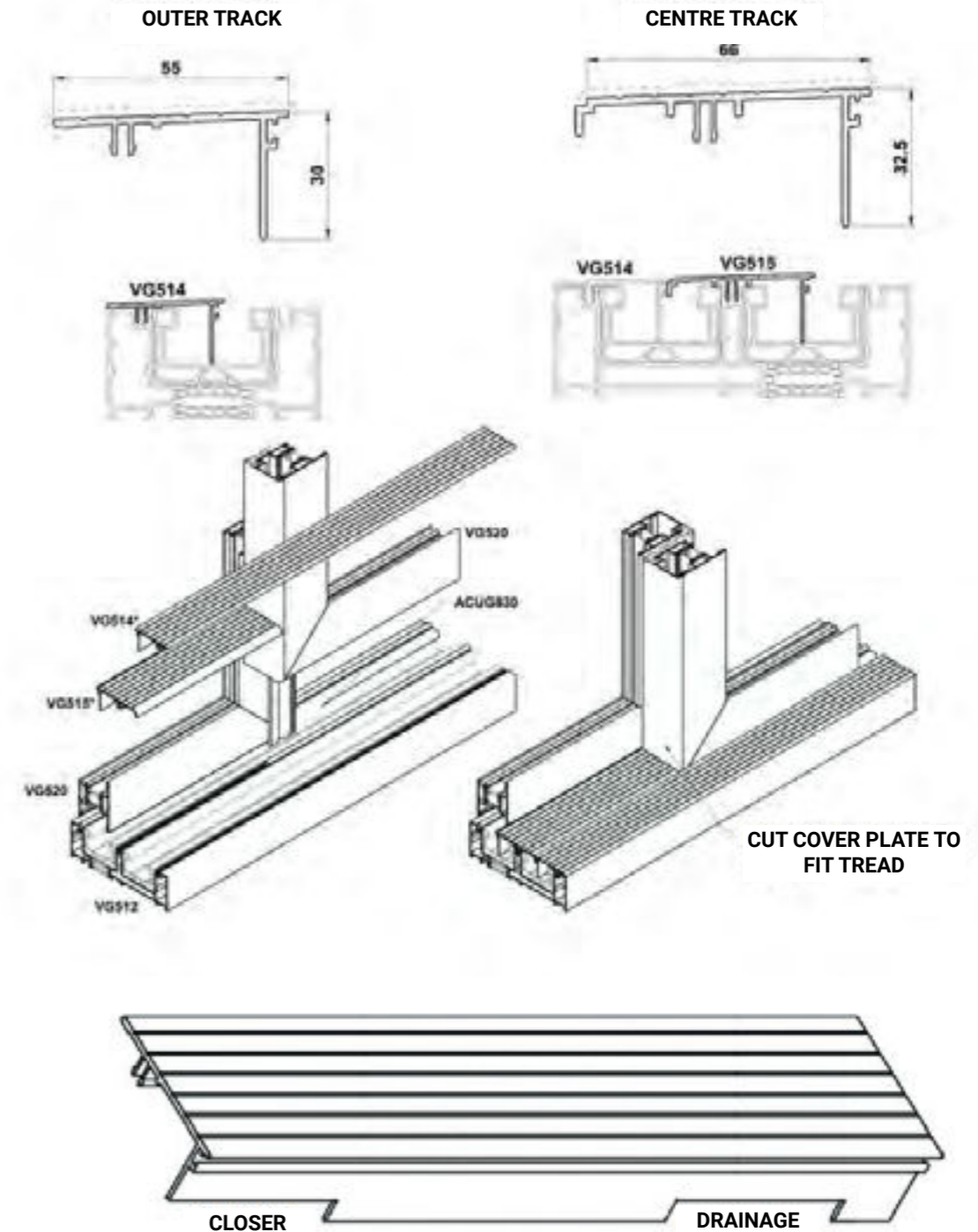

The bottom tread will have notches for the drainage.

The notches fit around the frame closers (see FRAME CLOSERS page)



NOTES: